



## Stem Extensions

### EX - SERIES

**Heavy Duty, Rugged Construction**  
**Investment Cast Stainless Steel**  
**Improved Accessibility**  
**Easy Installations**



**3" tall design adapts to the following Fusion Valve Series & sizes:**  
**T23/S23**  
**valve sizes 1/4"-2"**

**4" tall design adapts to the following valve models & sizes:**  
**F150/F300/200/300/HPF/HPS**  
**valve sizes 1/4"-2", 2 1/2", 3", 4"**



**6" tall design adapts to the following valve models & sizes:**  
**F150/F300**  
**valve sizes 6", 8"**

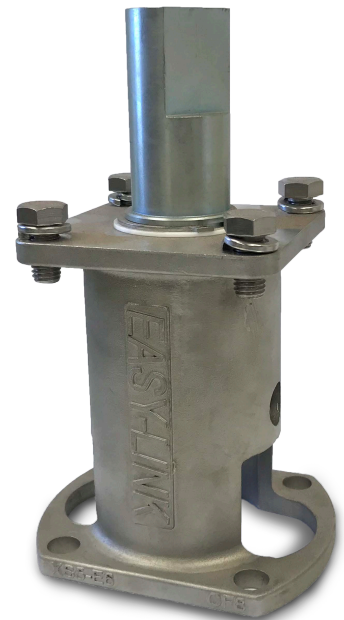

**Ideal for Use In Insulated Pipelines**

Flo-Tite's EX-Series Stem Extension is designed to provide safer installations. This stem extension provides additional height and helps add distance between the valve and operator. This protects automation from dangerous temperature media that may be present in the pipeline. This also allows handle gear actuation access while providing space for pipe and valve insulation.

**Model Type A (lockable)**

XS1-E4 / XS2-E4 / XS3-E4 / XS4-E4  
 1/4"-3/4" / 1", 1 1/4" / 1 1/2", 2" / 2.5", 3", 4"

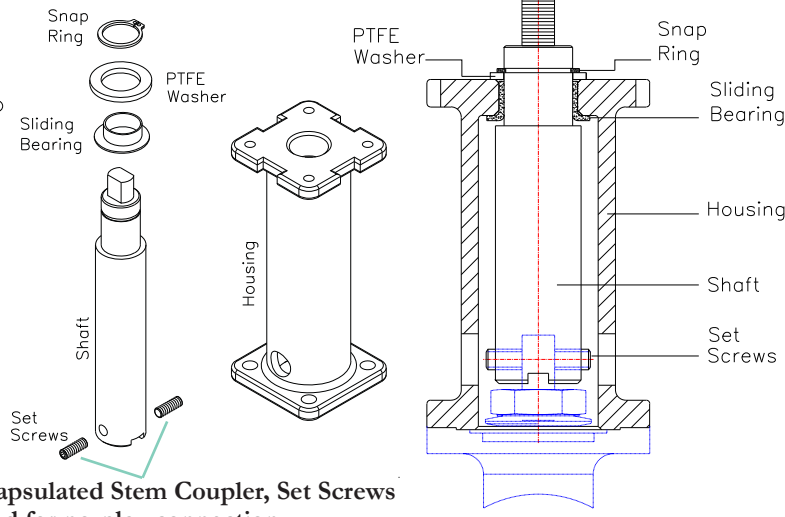
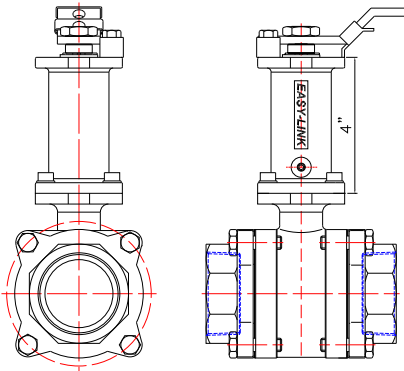

Encapsulated Stem Coupler, Set Screws added for no-play connection.

XS4-E4  
 2 1/2", 3", 4"

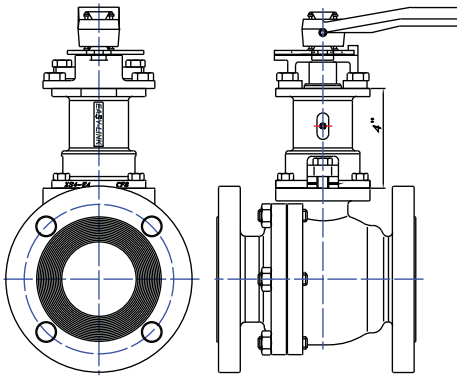

XS5-E6  
 6", 8"

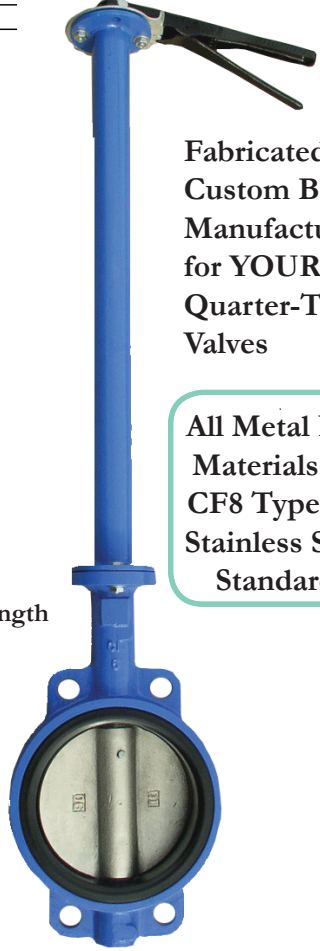
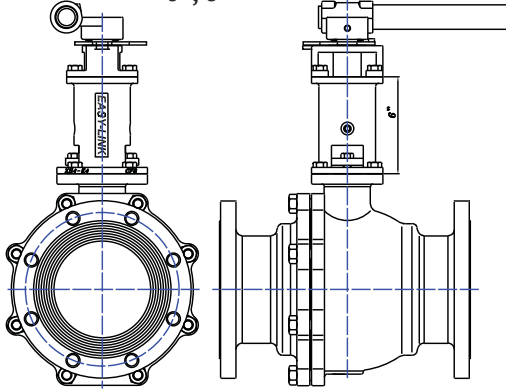

Fabricated  
 Custom Built  
 Manufactured  
 for YOUR  
 Quarter-Turn  
 Valves

All Metal Part  
 Materials are  
 CF8 Type 304  
 Stainless Steel  
 Standard.

**Model Type C**

XM1-E3 / XM2-E3 / XM3-E3 / XM4-E3  
 1/4"-1/2" / 3/4" / 1", 1 1/4" / 1 1/2", 2"

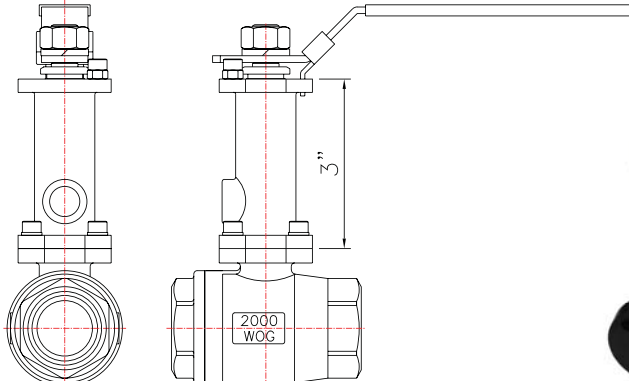

Unlockable Type  
 Custom Design 1"-4" Length



Flo-Tite, Inc.  
 4815 West 5th St.  
 Lumberton, NC 28358

P. O. Box 1293  
 Lumberton, NC 28359  
 Website: www.flotite.com

Tel: (910) 738-8904  
 Fax: (910) 738-9112  
 E-mail: flotite@flotite.com

Due to continuous development & improvement of our product range, we reserve the right to alter the dimensions and technical data included in this brochure.