



2PC Full Bore Economical Ball Valves

2PC ECONOFLO SERIES

Model : T82SS

1000 WOG / 150 SWP

316 Stainless Steel

Optional Carbon Steel

Optional 304SS

Temperature Range:

-20 °F to 450 °F

-28.9 °C to 232 °C

Size Range:

1/4" - 3"

Threaded Ends



DESIGN FEATURES

- Full Port - Straight through flow minimizes pressure drop and prolongs valve life
- Internal Entry Blow-out Proof Stem
- Locking Handle - Optional that meets OSHA 1910.147
- Adjustable V-Ring Stem Packing
- Bubble Tight - Zero Leakage
- Investment cast improves dimensional control and reduces porosity
- 2PC Econoflo Series is an ideal general purpose stainless steel valve, meeting plant - wide applications

Econoflo Series offers exceptional economy and proven performance

T82SS Full Port Ball Valve Design & Technical Data

Model Number:
T82SS-RRR-L

DIMENSIONS AND WEIGHTS:

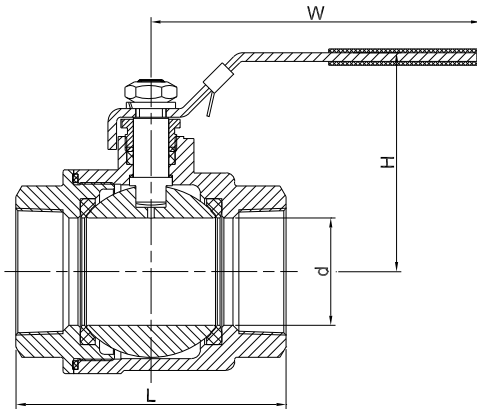

SIZE		1/4"	3/8"	1/2"	3/4"	1"	1 1/4"	1 1/2"	2"	2 1/2"	3"
L	inch	2.09	2.09	2.52	2.87	3.31	3.78	4.17	4.80	6.26	6.97
	mm	53	53	64	73	84	96	106	122	159	177
d	inch	0.45	0.45	0.59	0.79	0.98	1.26	1.50	1.93	2.56	3.07
	mm	11.5	11.5	15	20	25	32	38	49	65	78
H	inch	1.93	1.93	2.20	2.40	2.76	2.91	3.50	4.02	4.84	5.28
	mm	49	49	56	61	70	74	89	102	123	134
W	inch	3.66	3.66	4.02	4.45	5.71	5.71	7.48	7.48	8.31	9.09
	mm	93	93	102	113	145	145	190	190	211	231
Cv		8	8	23	44	83	108	168	266	469	666
Torque (in-lb)		71	71	89	89	106	133	177	354	443	620
Weight (lbs)		0.6	0.8	0.8	1.0	1.6	2.6	3.7	4.6	10.0	14.6

*Dimensions are for estimating purpose only.
Please consult factory for exact dimensions.*

BILL OF MATERIALS:

Item	Name	T80SS
1	Body	ASTM A351 CF8M
2	End Cap	ASTM A351 CF8M
3	Ball	SS316
4	Seat	RPTFE
5	Gasket	RPTFE
6	Stem	SS304
7	Washer	RPTFE
8	Stem Packing	RPTFE
9	Gland Nut	SS304
10	Handle	SS420
11	Locking Pad	SS420
12	Handle Sleeve	PVC
13	Spring Washer	SS304
14	Nut	SS304

*All valves 100% air tested underwater
at 100 psi Open and Close positions.*

T82SS Conforms to:
Federal Specification WW-V-35B
Type II, Class C Style 3

Pipe Thread in accordance with
ANSI B1.20.1

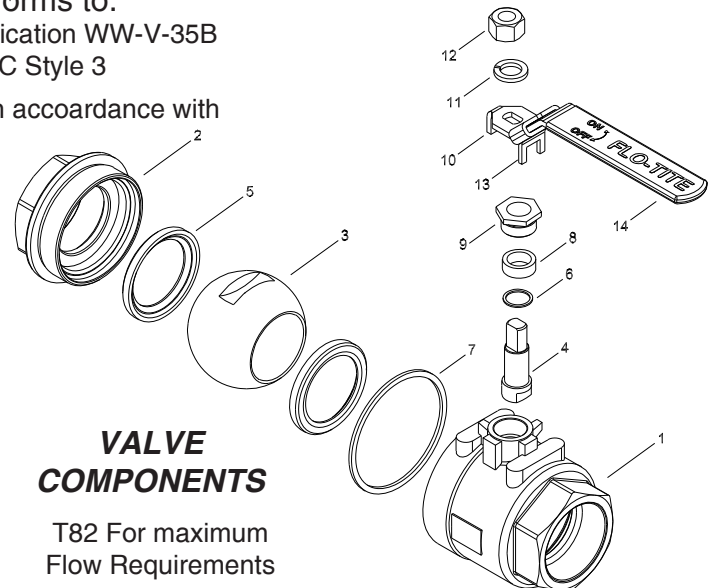

VALVE COMPONENTS

T82 For maximum
Flow Requirements

Note: Our T82 Series Valves Are Not Designed
To Be Actuated. Please See Our T23 Series
Tech Bulletin Page 14

PRESSURE AND TEMPERATURE DATA

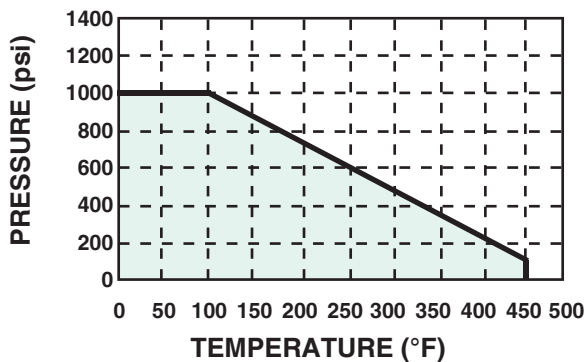

PRESSURE RATING: 1000 WOG

ATTENTION
MAWP/WOG is a do-not exceed
pressure at normal ambient
NPT & Weld End Models