



3 & 4 WAY MULTI-PORT BALL VALVES

TRANS~Flo Series

Extremely Versatile Valve Design for Flow Diversion or Mixing



Models:

Flanged End

ANSI/Class 150 MPF15
ANSI/Class 300 MPF30
ANSI/Class 600 MPF60

Threaded End

800 WOG MPT30

Tri-Clamp End

150 WOG MPC15

Custom End Connections



Sizes:

3/4" - 14" Flanged End

1/2" - 4", NPT & Tri-Clamp

DESIGN FEATURES

- One Piece Ball/Stem Trunnion - Supported Type
- Three Seat Design Maintains Proper Ball Position, four Seat Design Optional
- Actuator Mounting Flange ISO-5211
- Anti-Static Grounding Device
- Open And Closed Locking Device for Positional Safety Lockout to 6" 8", 10", and 12" Optional
- Flow Plans for Both T & L Ports can be field rearranged to meet many other Flow Options.
- Both T & L Valves can be offered with an off position.
- Body Cavity fillers for sizes 3/4" - 6"
- Full Port 1/2" - 12", Standard Bore 6" - 12"
- Handle Operated 1/2"-4", 6" & Larger, Gear Operator Standard

Simplify All Aspects of Piping Systems with Flo-Tite's Multiport Ball Valves.

Cut-Away View

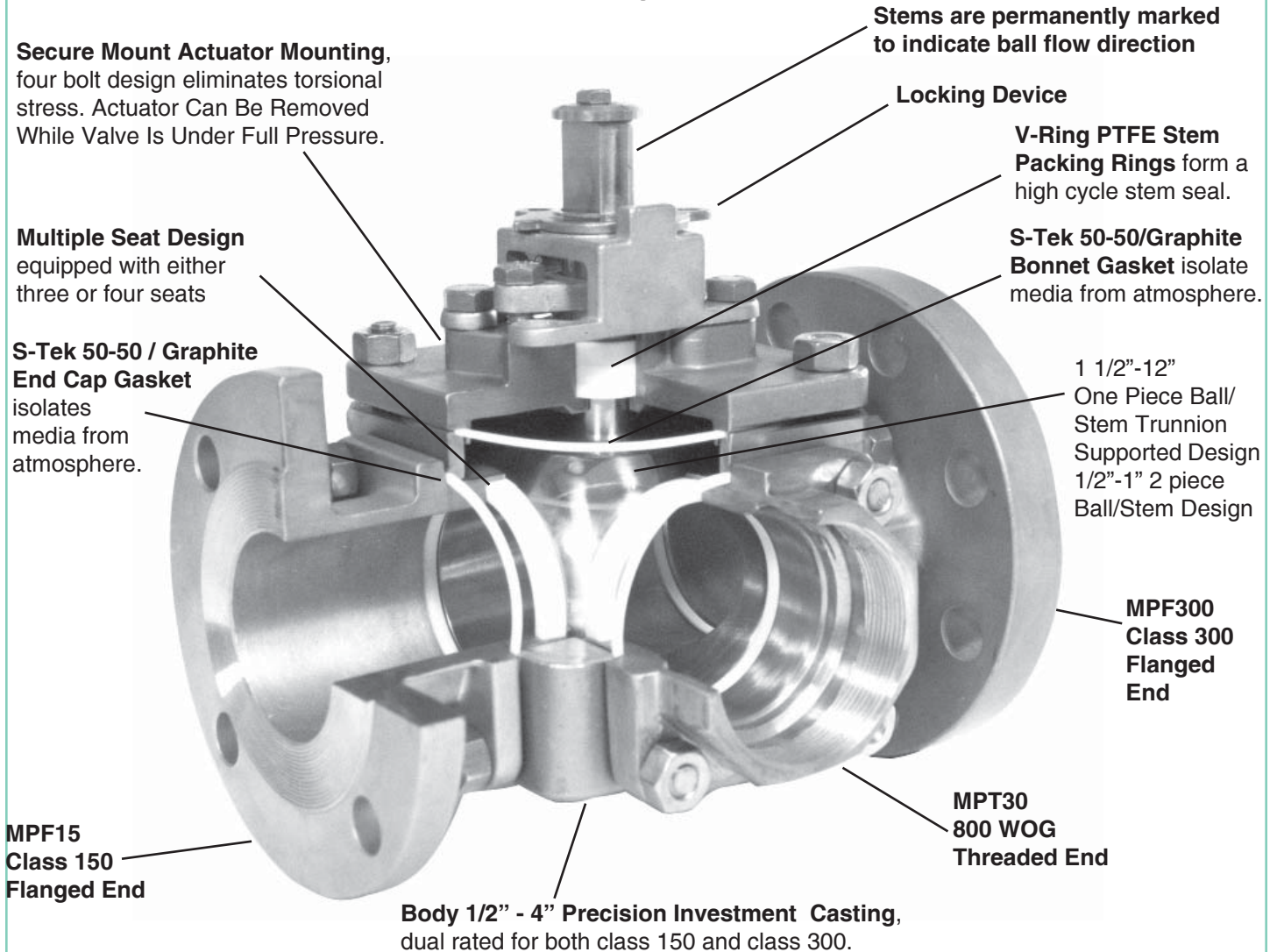

VALVE OPTIONS AND MODELS

Body Cavity Fillers designed to reduce the possibility of contamination by entrapment of process fluids in the void normally found behind the ball and the valve body.

Flo-Tite can supply **various seat materials** to handle a wide variety of special applications.

Severe service valves are available with hard face metal seats, shutoff class V.

Special Alloys such as Alloy 20, 316L, Duplex, Monel and Hastelloy are available.

MPF15 Full Port Flanged End, Class 150
 Sizes **1/2" thru 14"**

MPF30 Class 300

MPF60 Class 600

MPSF15 Reduced Port Flanged End, Class 150, sizes 6" thru 12"

MPT30 Full Port Threaded sizes 1/2" - 3"

MPC15 Full Port Clamp End sizes 1/2" - 4"

Different End Connections may be combined to meet specific requirements, as our heavy duty body for all models conforms to ANSI Class 300, sizes 1/2" thru 4"

Sizes:
1/2" - 1"
Exploded View

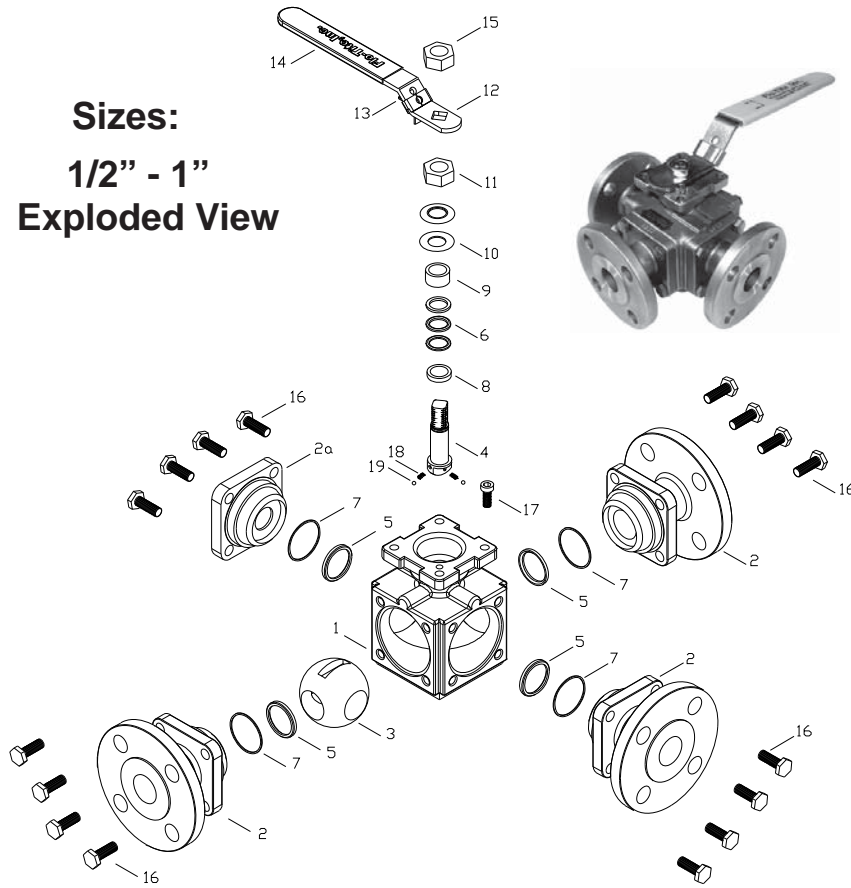

Bill of Materials 1/2" - 1"

Item	Component	Stainless Steel	Carbon Steel	Qty
1	Body	ASTMA351 CF8M	ASTMA216 WCB	1
2	End Caps	ASTMA351 CF8M	ASTMA216 WCB	3
2a	Back Cover	ASTMA351 CF8M	ASTMA216 WCB	1
3	Ball	SS316	SS304 / SS316	1
4	Stem	SS316	SS304 / SS316	1
5	Seats	# TFM	TFM	4
6	Stem Packing	# TFM / Graphite	TFM / Graphite	1
7	Body Gaskets	# 50/50 / Graphite	50/50 / Graphite	4
8	Thrust Washer	# 50/50	50/50	1
9	Packing Follower	SS304	SS304	1
10	Belleville Washer	SS301	SS301	2
11	Stem Nut	SS304	SS304	1
12	Handle	SS304	SS304	1
13	Handle Lock	SS304	SS304	1
14	Handle Sleeve	Plastic	Plastic	1
15	Handle Nut	SS304	SS304	1
16	Body Bolts	ASTMA193 B8	ASTMA193 B7	16
17	Handle Stop Bolt	SS304	SS304	1
18	Anti-Static Springs	SS316	SS316	2
19	Anti-Static Balls	SS316	SS316	2

Parts included in the repair kits

Bill of Materials 1 1/2" - 2"

Item	Component	Stainless Steel	Carbon Steel	Qty
1	Body	ASTMA351 CF8M	ASTMA216 WCB	1
2	End Caps	ASTMA351 CF8M	ASTMA216 WCB	3
3	Bonnet	ASTMA351 CF8M	ASTMA216 WCB	1
4	Ball & Stem	ASTMA351 CF8M	ASTMA351 CF8/CF8M	1
5	Seats	# TFM	TFM	3
6	Stem Packing	# TFM / Graphite	TFM / Graphite	1
7	Body Gaskets	# 50/50 / Graphite	50/50 / Graphite	3
8	Bonnet Gasket	# 50/50 / Graphite	50/50 / Graphite	1
9	Thrust Bearing	# 50/50 / PEEK	50/50 / PEEK	1
10	Anti-Static Spring	SS304	SS304	1
11	Bonnet Bolts	ASTMA193 B8	ASTMA193 B7	4
12	Bonnet Nuts	ASTMA194 Gr. 8	ASTMA194 2H	4
13	Packing Follower	SS304	SS304	1
14	Packing Gland	SS304	Steel	1
15	Gland Bolts	SS304	Steel	2
16	Handle	SS304	SS304	1
17	Handle Lock	SS304	SS304	1
18	Handle Sleeve	Plated Steel	Plated Steel	1
19	First Snap Ring	Plated Steel	Plated Steel	1
20	Second Snap Ring	Plated Steel	Plated Steel	1
21	Body Studs	ASTMA193 B8	ASTMA193 B7	12
22	Body Nuts	ASTMA194 Gr. 8	ASTMA194 2H	12
23	Handle Stop Nut	SS304	SS304	1
24	Handle Stop Bolt	SS304	SS304	1

Parts included in the repair kits

1 1/2" - 2"
Exploded View

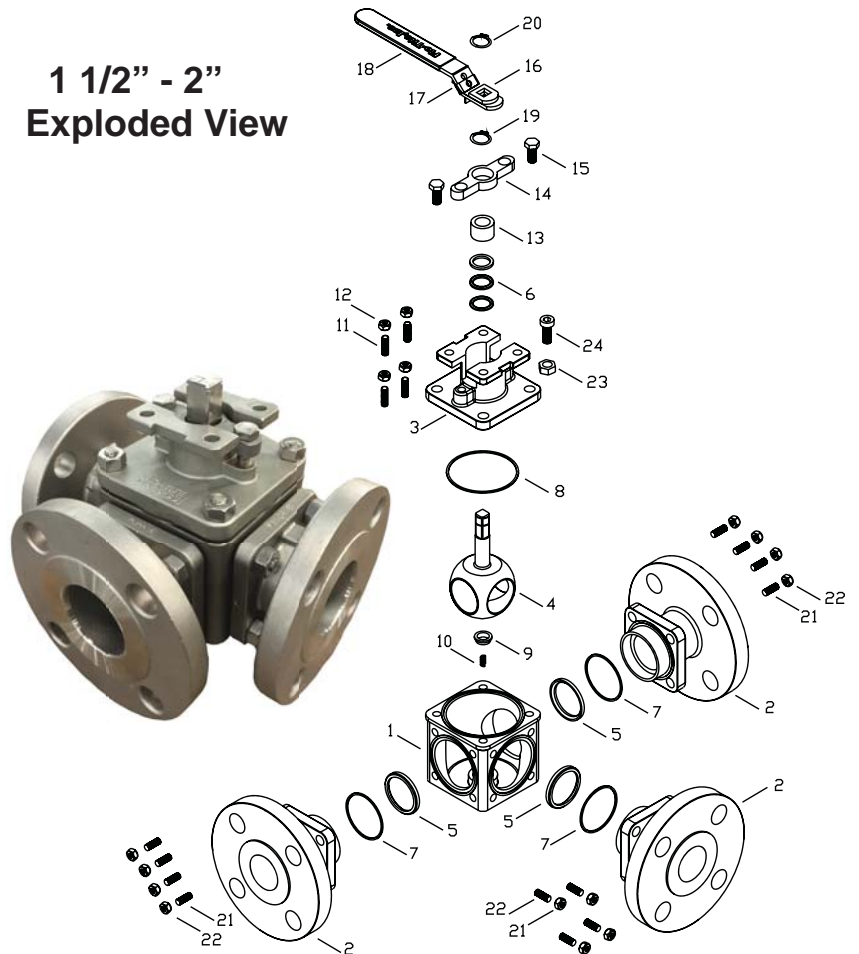

Bill of Materials 2 1/2" - 4"

Item	Component	Stainless Steel	Carbon Steel	Qty
1	Body	ASTM A351 CF8M	ASTM A216 WCB	1
2	End Caps	ASTM A351 CF8M	ASTM A216 WCB	3
3	Bonnet	ASTM A351 CF8M	ASTM A216 WCB	1
4	Ball & Stem	ASTM A351 CF8M	ASTM A351 CF8/CF8M	1
5	Seats	# TFM	TFM	3
6	Stem Packing	# TFM / Graphite	TFM / Graphite	1
7	Body Gaskets	# 50/50 / Graphite	50/50 / Graphite	3
8	Bonnet Gasket	# 50/50 / Graphite	50/50 / Graphite	1
9	Thrust Bearing	# 50/50 / PEEK	50/50 / PEEK	1
10	Anti-Static Spring	SS304	SS304	1
11	Bonnet Bolts	ASTM A193 B8	ASTM A193 B7	set
12	Bonnet Nuts	ASTM A194 Gr. 8	ASTM A194 2H	set
13	Packing Follower	SS304	SS304	1
14	Packing Gland	ASTM A351 CF8	ASTM A216 WCB	1
15	Gland Bolts	SS304	Steel	2
16	Housing Bolts	SS304	Steel	4
17	Stop Housing	ASTM A351 CF8	ASTM A216 WCB	1
18	Travel Stop	SS304	SS304	1
19	Handle Screw	SS304	SS304	1
20	Handle	Ductile Iron	Ductile Iron	1
21	Snap Ring	Plated Steel	Plated Steel	1
22	Port Sign	SS304	SS304	1
23	Plain Washer	SS304	SS304	1
24	Sign Screw	SS304	SS304	1
25	Body Studs	ASTM A193 B8	ASTM A193 B7	set
26	Body Nuts	ASTM A194 Gr. 8	ASTM A194 2H	set

Parts included in the repair kits

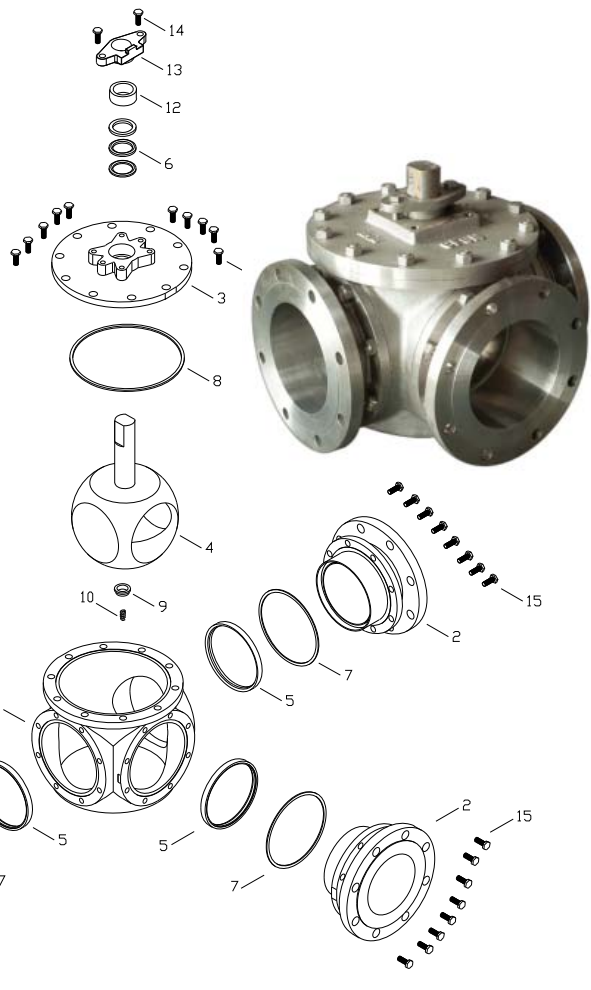
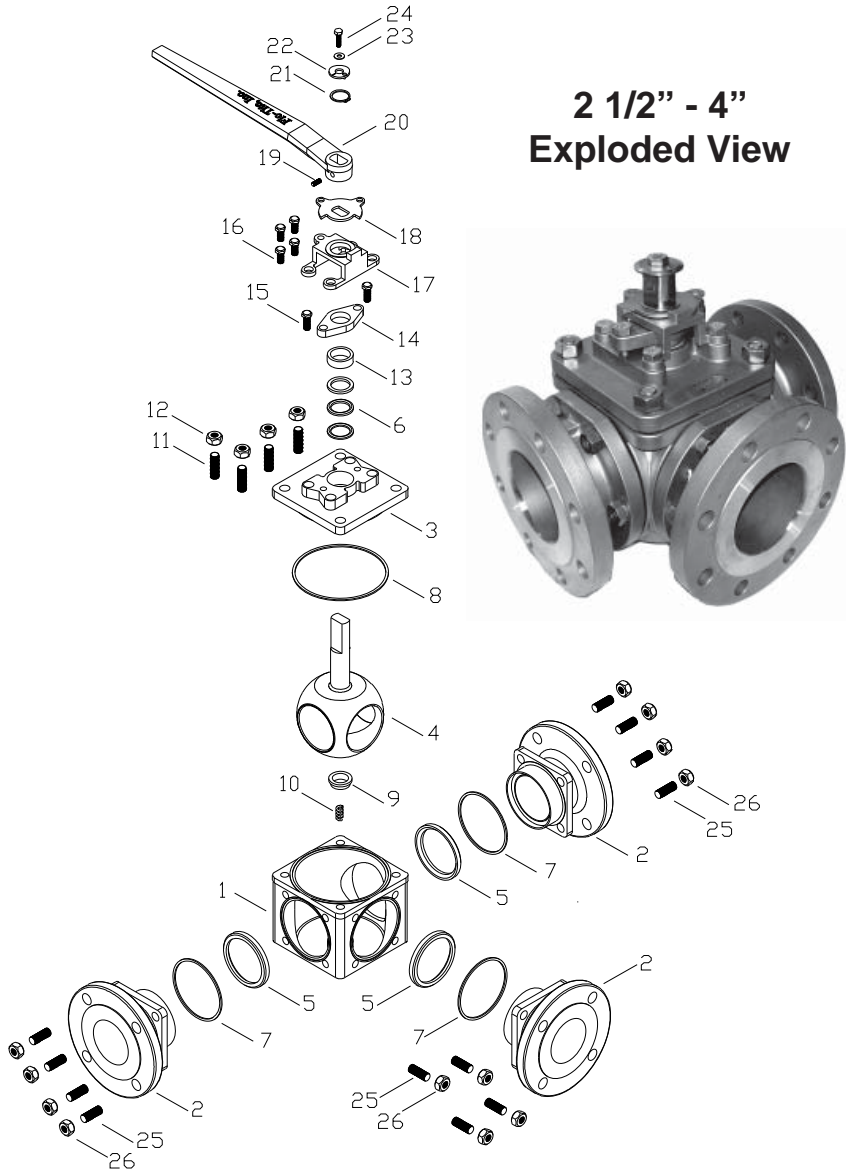

Bill of Materials 6" - 12"

Item	Component	Stainless Steel	Carbon Steel	Qty
1	Body	ASTM A351 CF8M	ASTM A216 WCB	1
2	End Caps	ASTM A351 CF8M	ASTM A216 WCB	3
3	Bonnet	ASTM A351 CF8M	ASTM A216 WCB	1
4	Ball & Stem	ASTM A351 CF8M	ASTM A351 CF8/CF8M	1
5	Seats	# TFM	TFM	3
6	Stem Packing	# TFM / Graphite	TFM / Graphite	1
7	Body Gaskets	# 50/50 / Graphite	50/50 / Graphite	3
8	Bonnet Gasket	# 50/50 / Graphite	50/50 / Graphite	1
9	Thrust Bearing	# 50/50 / PEEK	50/50 / PEEK	1
10	Anti-Static Spring	SS304	SS304	1
11	Bonnet Bolts	ASTM A193 B8	ASTM A193 B7	set
12	Packing Follower	SS304	SS304	1
13	Packing Gland	ASTM A351 CF8	ASTM A216 WCB	1
14	Gland Bolts	SS304	Steel	2
15	Body Bolts	ASTM A193 B8	ASTM A193 B7	set

Parts included in the repair kits

MPT30 NPT End

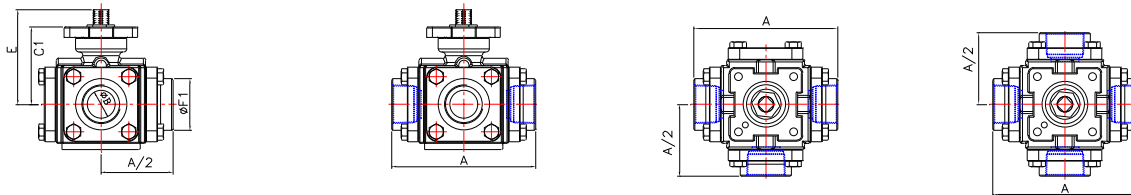

MPW30 Socket Weld End

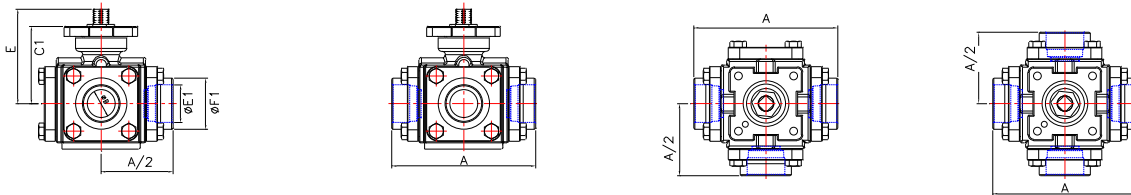

MPB30 Butt Weld End

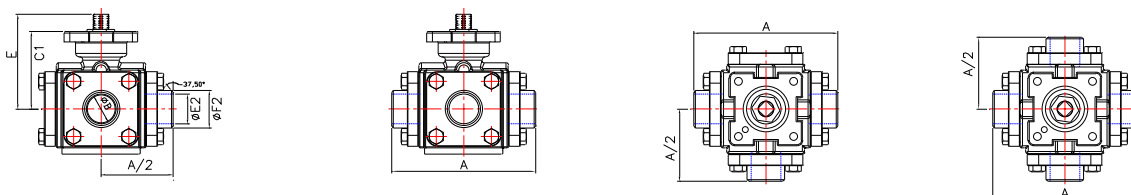

MPC30 Clamp End

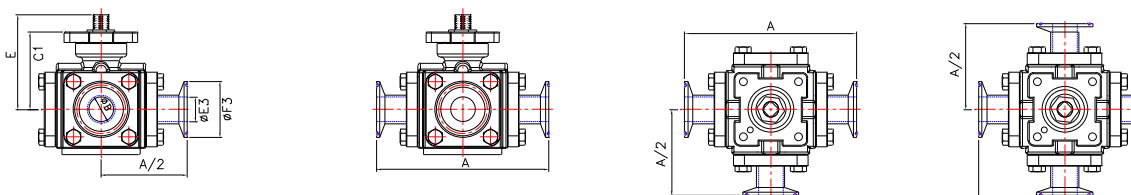

MPF15/MPF30 Flanged End Class 150/300

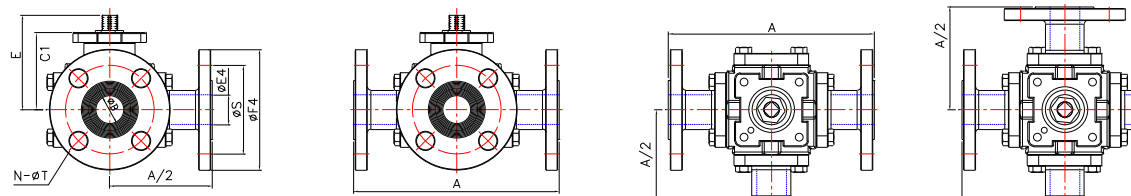

Standard Hand Lever Operated

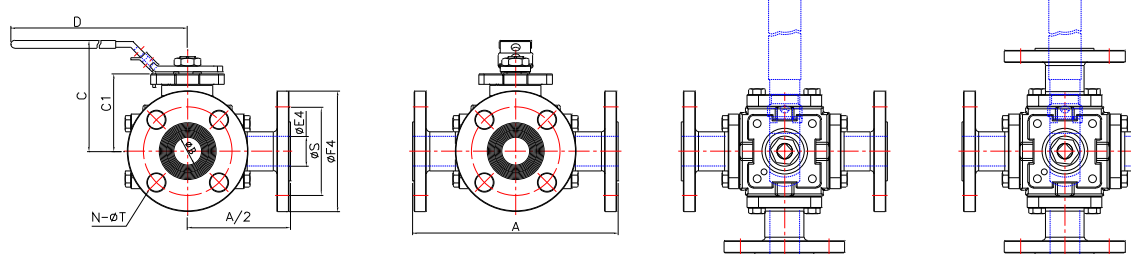

Full Port 1/2" - 1", Flanged End

Size	A		B	C	C1	D	E	F4		N		S		T	
	#150	#300						#150	#300	#150	#300	#150	#300	#150	#300
1/2"	6.17	C/F	0.50	3.18	1.93	7.13	2.50	3.50	3.75	4	4	2.38	2.62	0.62	0.62
3/4"	6.65	6.65	0.75	3.95	2.50	7.60	3.06	3.88	4.62	4	4	2.75	3.25	0.62	0.75
1"	7.25	7.48	1.00	4.09	2.73	8.25	3.28	4.25	4.88	4	4	3.12	3.50	0.62	0.75

Full Port 1/2" - 1", NPT, Socket Weld, Butt Weld, & Tri-Clamp End

Size	A				B	C	C1	D	E	E1	E2	E3	E4	F1	F2	F3
	npt	sw	bw	Clamp												
1/2"	3.66	3.66	3.66	5.21	0.50	3.18	1.93	7.13	2.50	0.854	0.622	0.370	0.567	1.102	0.840	0.984
3/4"	4.46	4.46	4.46	5.20	0.75	3.95	2.50	7.60	3.06	1.067	0.824	0.620	0.787	1.390	1.050	0.984
1"	5.04	5.04	5.04	5.59	1.00	4.09	2.73	8.25	3.28	1.331	1.049	0.870	0.984	1.654	1.315	1.984

MPT30 NPT End

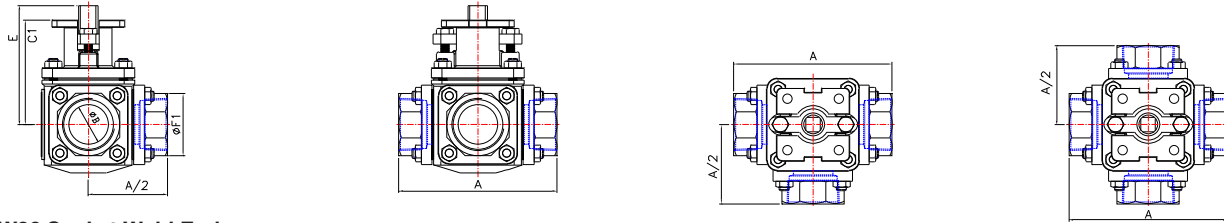

MPSW30 Socket Weld End

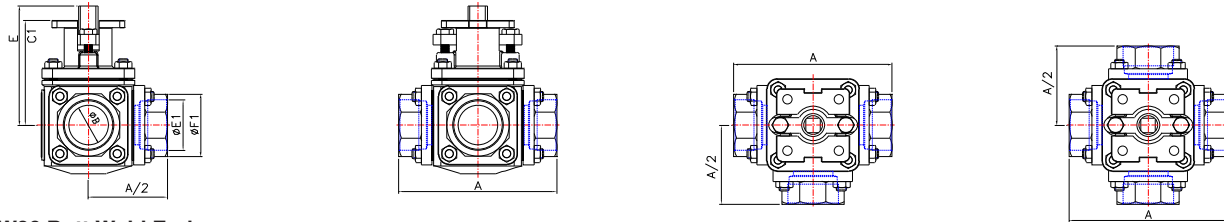

MPBW30 Butt Weld End

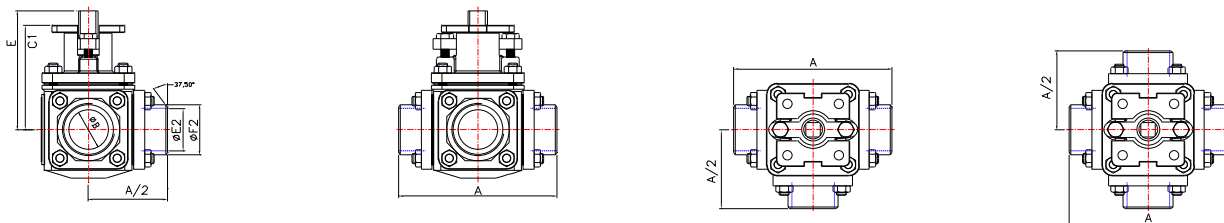

MPC30 Clamp End

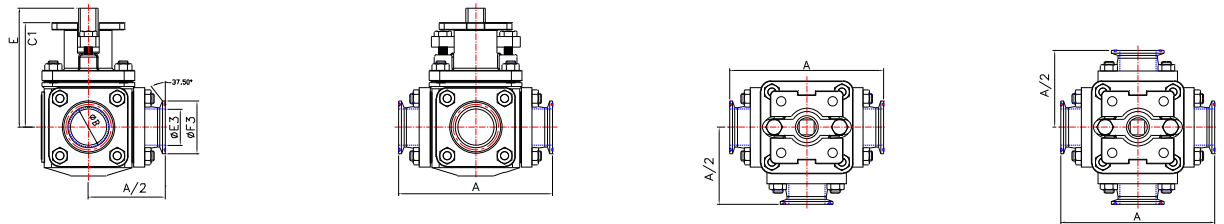

MPF15/MPF30 Flanged End Class 150/300

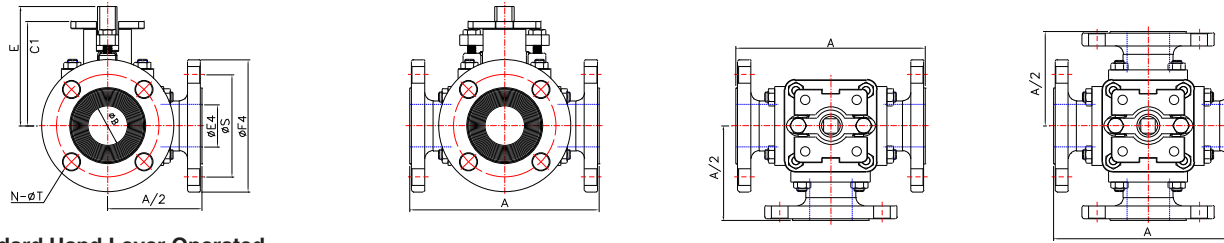

Standard Hand Lever Operated

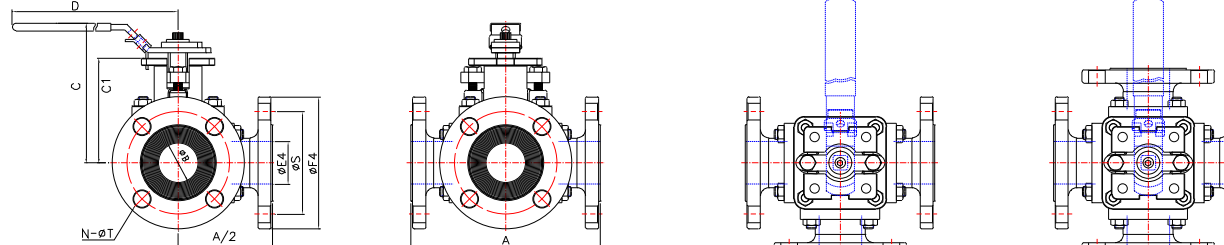

Full Port 1 1/2" - 2", Flanged End

Size	A		B	C	C1	D	E	F4		N		S		T	
	#150	#300						#150	#300	#150	#300	#150	#300	#150	#300
1 1/2"	7.17	8.62	1.57	6.40	4.04	10.41	4.74	5.00	6.14	4	4	3.88	4.50	0.62	0.87
2"	8.66	9.37	1.97	6.24	3.84	10.41	4.67	6.00	6.50	4	8	4.75	5.00	0.75	0.75

Full Port 1 1/2" - 2", NPT, Socket Weld, Butt Weld, & Tri-Clamp End

Size	A				B	C	C1	D	E	E1	E2	E3	E4	F1	F2	F3
	npt	sw	bw	Clamp												
1 1/2"	5.84	5.84	5.84	5.84	1.57	6.40	4.04	10.41	4.74	1.913	1.610	1.37	1.57	2.362	1.900	1.984
2"	6.50	6.50	7.26	7.09	1.97	6.24	3.84	10.41	4.67	2.406	2.067	1.87	1.97	2.913	2.375	2.515

MPT30 NPT End

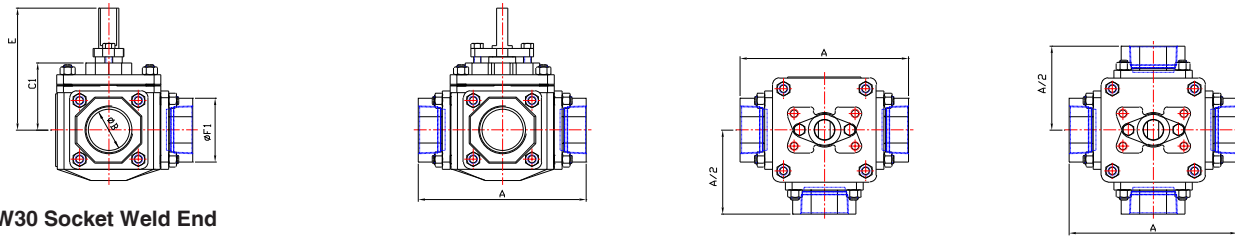

MPSW30 Socket Weld End

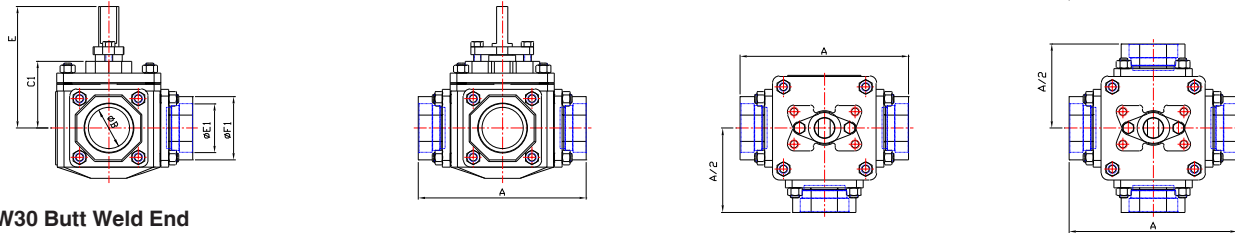

MPBW30 Butt Weld End

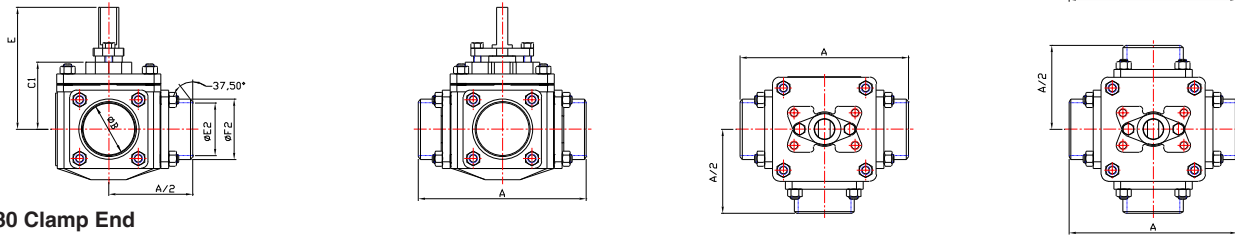

MPC30 Clamp End

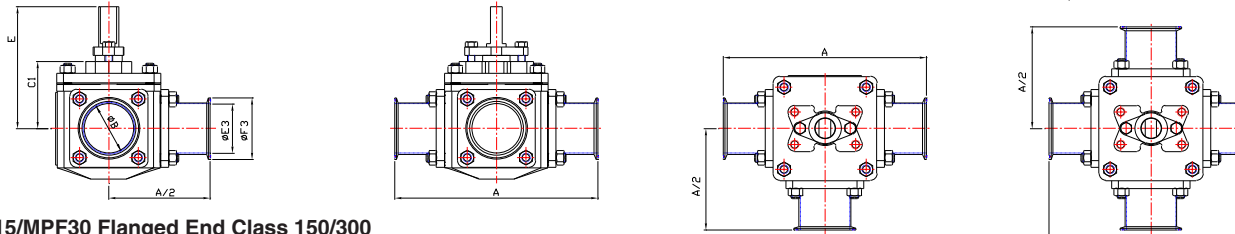

MPF15/MPF30 Flanged End Class 150/300

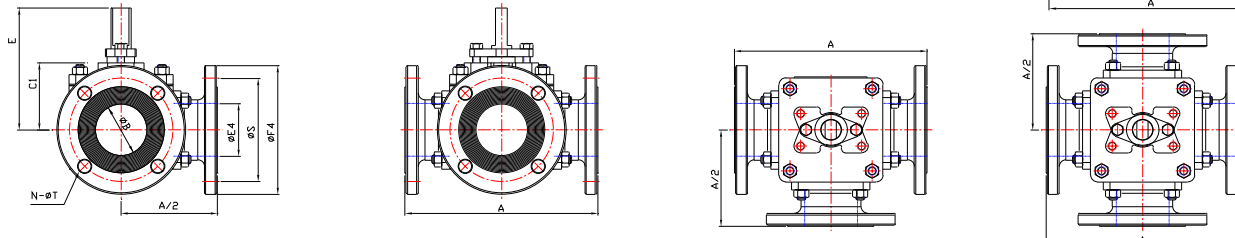

Standard Hand Lever Operated

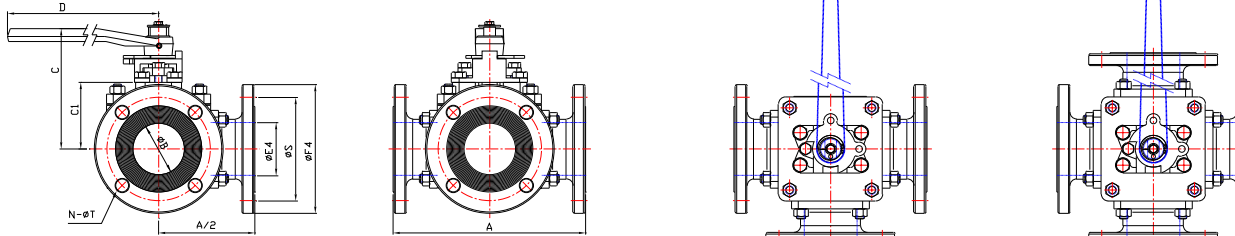

Full Port 2 1/2" - 4", NPT, Socket Weld, Butt Weld, & Tri-Clamp End

Size	A		B	C	C1	D	E	E1	E2	E3	E4	F1	F2	F3
	npt/sw/bw	Clamp												
2 1/2"	-	-	2.60	C/F	C/F	15.6	C/F	0.854	0.622	0.370	0.567	1.102	0.840	0.984
3"	9.76	12.08	2.99	5.76	3.86	15.6	6.85	1.067	0.824	0.620	0.787	1.390	1.050	0.984
4"	-	14.24	3.94	7.29	4.91	21.1	8.10	1.331	1.049	0.870	0.984	1.654	1.315	1.984

Full Port 2 1/2" - 4", Flanged End

Size	A		B	C	C1	D	E	F4		N		S		T	
	#150	#300						#150	#300	#150	#300	#150	#300		
2 1/2"	11.10	11.22	2.60	C/F	C/F	15.6	C/F	7.00	7.50	4	8	5.50	5.88	0.75	0.87
3"	11.26	11.85	2.99	5.76	3.86	15.6	6.85	7.50	8.25	4	8	6.00	6.62	0.75	0.87
4"	13.70	15.35	3.94	7.29	4.91	21.1	8.10	9.00	10.0	8	8	7.50	7.88	0.75	0.87

MPF15 Alternate A Dimension: 3" 11.6"; 4" 13.19;
 MPF30 Alternate A Dimension: 3" 12.20"; 4" 14.09

MPBW30 Butt Weld End

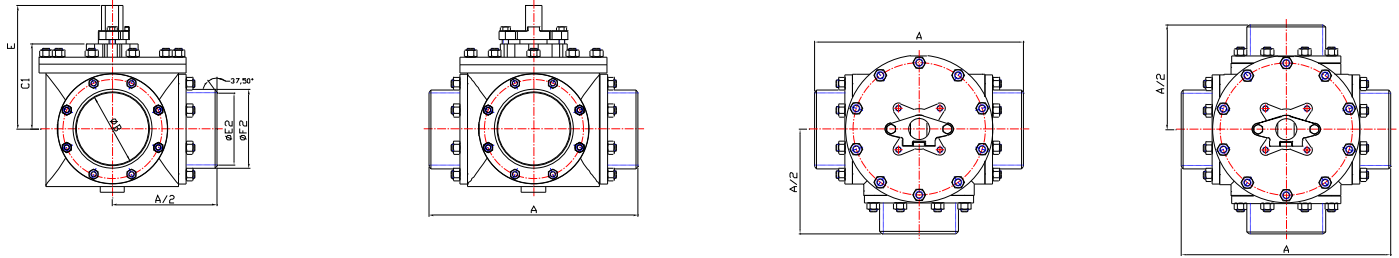

MPF15/MPF30 Class 150/300 Flanged End

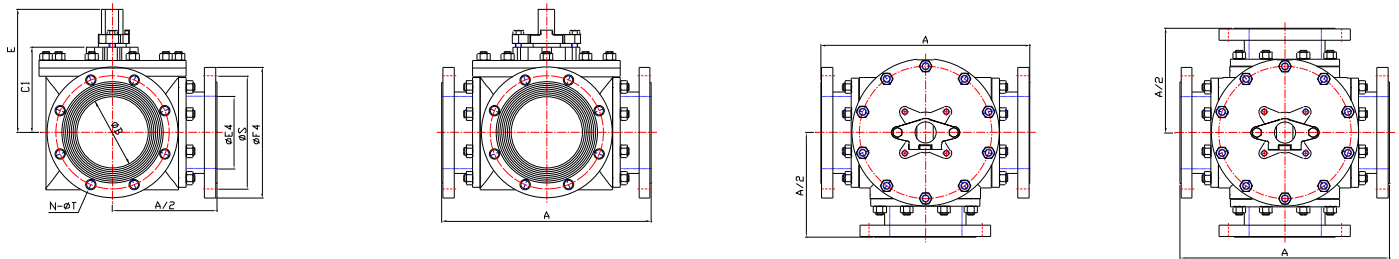

MPRF15/MPRF30 Class 150/300 Flanged End

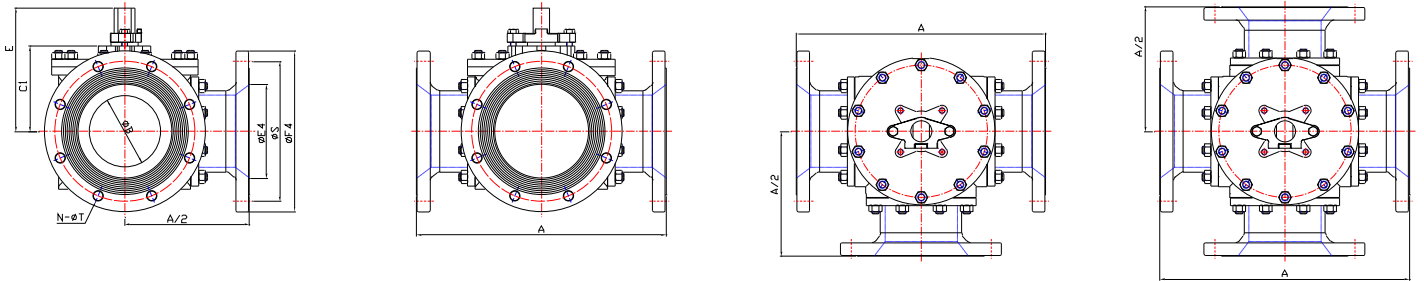

Full Port 6" - 12", Standard Face-to-Face

Size	A			B	C1	E	E2	E4	F2	Class 150				Class 300			
	BW	#150 flg	#300 flg							F4	N	S	T	F4	N	S	T
6"	N/A	17.56***	18.42	5.91	7.14**	10.37	6.07	5.91	6.625	11.0	8	9.50	0.87	12.5	12	10.62	0.87
8"	N/A	21.18	23.93	7.87	8.37**	11.91	7.98	7.87	8.625	13.5	8	11.75	0.87	15.0	12	13.00	1.00
10"	N/A	27.67	30.27	9.84	9.27	13.60	10.02	9.84	10.75	16.0	12	14.25	1.00	17.5	16	15.25	1.14
12"	N/A	30.31	31.53	11.81	10.24	14.96	11.94	11.81	12.75	19.0	12	17.00	1.00	20.5	16	17.75	1.25

**For 6", 8" class 300, C1 dimension is 7.38, 8.54 respectively

***6" MPF15 Alternate A Dimension: 16.92"

C1, H dimensions may vary within ± 2 mm or ± 0.08"

Reduced Port 6" - 12", Standard Face-to-Face

Size	A			B	C1	E	E2	E4	F2	Class 150				Class 300			
	BW	#150 flg	#300 flg							F4	N	S	T	F4	N	S	T
6"	N/A	16.85	N/A	3.94	5.04	8.20	6.07	5.91	6.625	11.0	8	9.50	0.87	12.5	12	10.62	0.87
8"	N/A	20.94	N/A	5.91	7.16	10.15	7.98	7.87	8.625	13.5	8	11.75	0.87	15.0	12	13.00	1.00
10"	N/A	26.77	N/A	7.87	8.36	11.90	10.02	9.84	10.75	16.0	12	14.25	1.00	17.5	16	15.25	1.14
12"	N/A	29.57	N/A	9.84	9.72	13.80	11.94	11.81	12.75	19.0	12	17.00	1.00	20.5	16	17.75	1.25

SPECIFICATION STANDARDS:

Flanges ANSI B16.5
Shell/Wall ANSI B16.34

Federal Specifications:
WWV-V-35B Valve, Ball, Type II
Class C, Style 3, End Connection B

ABS Type Approval:
Product Design
Assessment (PDA)

All Flo-Tite's ball valves are designed, constructed, and tested in strict accordance with the most current international standards, such as API, ASME, BS and DIN.

Flo-Tite's Quality Control Guarantee is established according to rigorous QA/QC procedures. We obtain high quality products by strict observance of these procedures throughout every stage of production. Material Test Reports (MTR) are available for all valve series. MPF valves are rated to 150 psi saturated steam/250 SWP with special seats.

PRESSURE AND TEMPERATURE DATA:

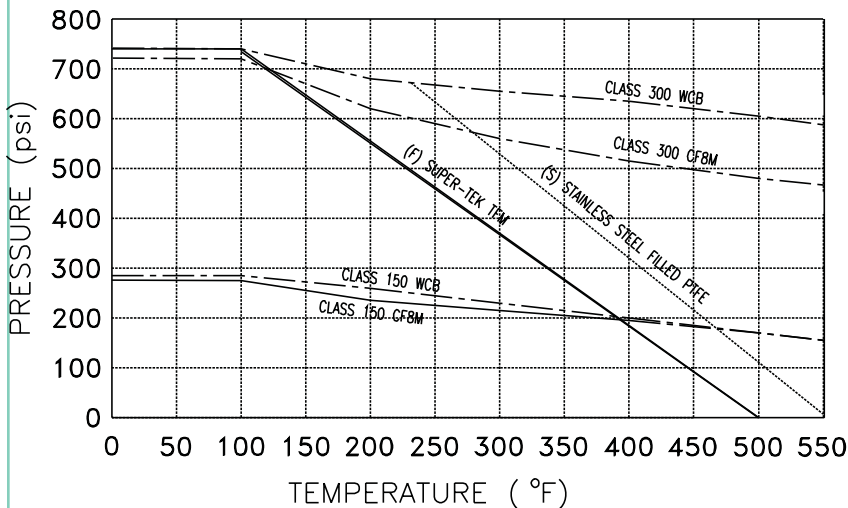

Pressure Test 100%
ANSI B16.34 / API 6D

Shell / Hydro Test Pressure:
Class 150 425 psi or 30 bar
Class 300 740 PSI or 51 bar
Optional 1100 psi or 76 bar

Seat / Air Test Pressure:
Class 150 80 psi or 6 bar
Class 300 80 psi or 6 bar

Rating Curve applies to both "L" and "T" port configurations.

All Values conform to ANSI Class pressure ratings. They are rated for a maximum differential pressure of 275 psi, and a maximum temperature of up to 550 °F. WCB - 285 psi Max. Complies with ANSI B16.5 and B16.34 standards.

ATTENTION
MAWP/WOG is a do not exceed pressure at normal ambient NPT & Weld End Models

Extended Pressures and temperatures may be achieved by altering designs. For specific applications, consult factory with service condition. If thermal cycles in excess of 200° are expected, use fire safe design trim.

Fire Safe Design

Flo-Tite's multiport valves can be fitted with graphite body seals and stem packing. This will make the valve fire safe to atmosphere by preventing external leakage that may add to fire intensity.

Cavity Fillers

Optional cavity fillers are available for multiport ball valves. Cavity fillers reduce the possibility of media build-up due to line media fluids becoming entrapped in the cavity between the ball and the valve body wall.

Seat Selection

A wide range of seat materials are available to meet most applications. The standard seat is TFM. Options include (R) RPTFE, (S) 50-50, (Y) Carbon Filled TFM, (P) PEEK, and (M) hardfaced metal.

Direct Mount Capability

2" and smaller sizes are designed to be directly flush mounted with actuators. The integrally cast top flange ensures positive actuator mounting. The mounting flange is designed to ISO 5211 standard.

Trunnion Support Design

One piece stem/ball trunnion support design provides for precise operation of the ball rotation. This precise ball positioning is often not possible in more common multi-piece stem ball designs.

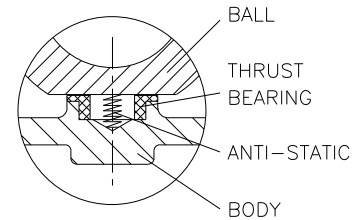

Standard Anti-Static Device

All valves are standard with anti-static grounding device.

Standard Locking Device

All valves can be padlocked to limit unwanted access.

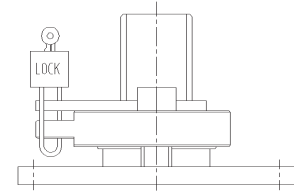

Multiple Seat Design

Flo-Tite's multi-port valves are equipped with three seats as standard. This allows all sides to be used as an inlet or block port without leakage. It also aids in balancing the ball for optimal control during modulation. An optional fourth seat can also be added to insure the highest level of performance; excellent for high cycle control automation requirements. The fourth seat is provided as standard on all four designed valves.

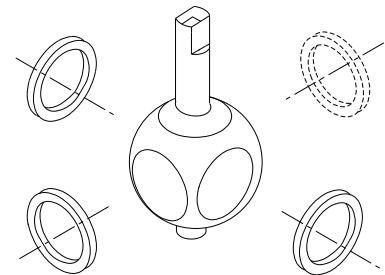

Flow Indication

All valve stems are marked with flow path direction

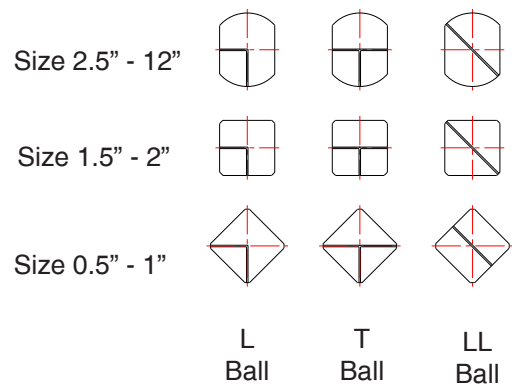

Typical Ball Configuration

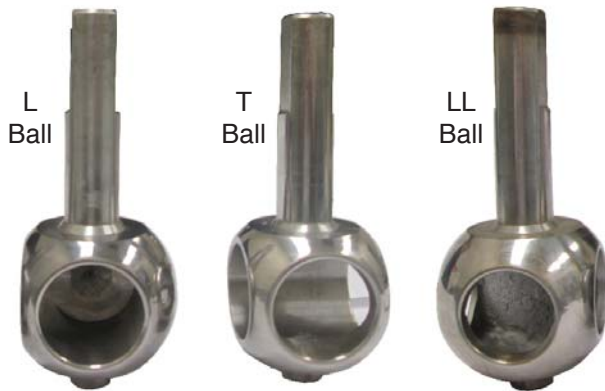

Pig Catcher Ball

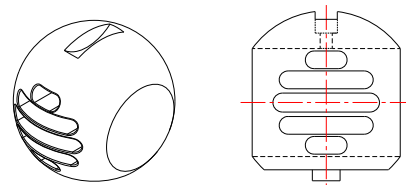

Multiport Ball Valve Advantage

Flo-Tite's Multiport Ball Valves are excellent alternatives for plug valves offerings:

- Lower Operating Torques
- Ease of Maintenance
- Low Cost of Repair
- Substantially Larger Ports, Maximum Cv's
- Ease of Actuation, With Our Secure Mount Design
- All T Port Flow Plans are Available From One Ball and can be Field Re-Arranged.
- Require less Space for Installation as all Pipe Connections are Level Plane, Most Plug Valves are Bottom Entry.

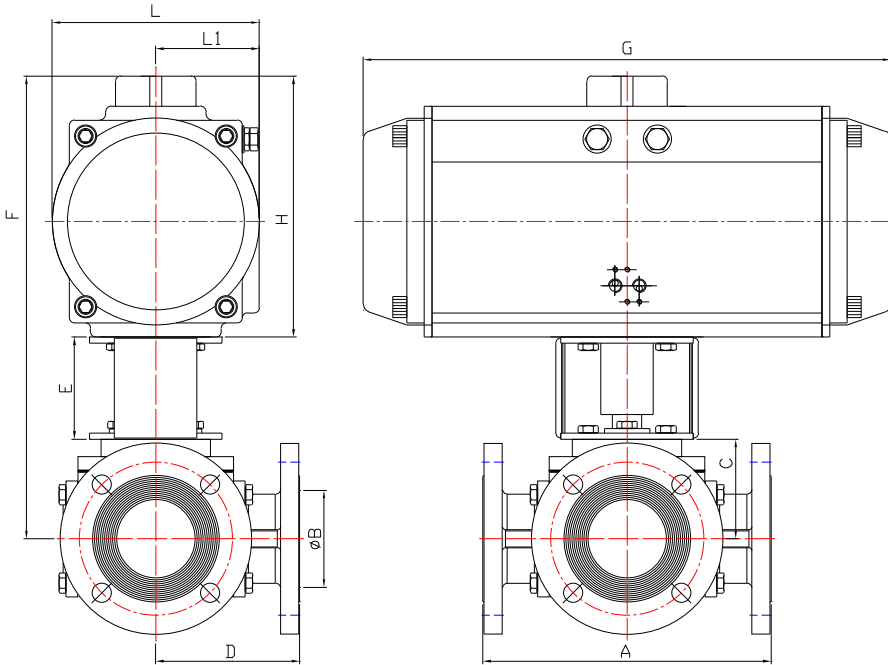

Pneumatic Actuator Dimensions shown in this drawing are for full port units based on 80 psi air to actuator, valves with standard Super-Tek TFM (F) seats, clean fluid only at ambient temperatures, and pressures not to exceed 800 WOG. Consult factory for additional actuator types and dimensional drawings.

All units are generally sized for clean wet service, actuator supply air 80 psi

Torque Factors for Special Applications:

- 1 - increase the breakaway torque by 20% for dry gas service or demineralized water
- 2 - add 10% for infrequent cycling
- 3 - add 40% for slurry or light abrasive content
- 4 - add 60% for metal seated valves, class V shut-off
- 5 - deduct 10% for high lubricity service

Torque figures are for valves up to 800 psi service. For higher pressure applications consult factory. Valve torque can vary due to pressure, media, and temperature.

The information provided above should be considered as a guide only and must be adjusted according to experience and judgment.

All Multiport Valves have integrally cast mounting pads for ease of mounting actuation equipment.



Double Acting Pneumatic Actuator:

SIZE	A	B	C	D	E	Actuator	F	G	H	L	L1
1/2"	6.17	0.50	2.60	3.09	1.57	DA063	8.40	6.61	4.23	3.27	1.85
3/4"	6.65	0.75	2.62	3.33	1.57	DA063	8.42	6.61	4.23	3.27	1.85
1"	7.25	1.00	2.66	3.63	1.57	DA075	8.93	7.24	4.70	3.74	2.09
1 1/2"	7.17	1.57	2.32	3.59	1.88	DA083	9.27	8.03	5.07	4.05	2.24
2"	8.66	1.97	2.76	4.33	1.88	DA092	10.03	10.31	5.39	4.27	2.30
2 1/2"	11.10	2.60	3.74	5.55	4.00	DA105	13.76	10.55	6.02	4.78	2.52
3"	11.26	2.99	3.78	5.63	4.00	DA125	14.67	11.65	6.89	5.59	2.93
4"	13.70	3.94	4.84	6.85	4.00	DA140	16.38	15.35	7.54	5.98	3.03
6"	17.56	5.91	7.09	8.78	4.00	DA190	21.33	20.79	10.24	8.12	4.06
8"	21.18	7.87	8.15	10.59	6.00	DA240	26.71	23.70	12.56	10.24	5.12
10"	27.67	9.84	8.62	13.84	6.00	DA300	29.52	29.20	14.90	12.80	6.40
12"	30.31	11.81	10.63	15.16	6.00	DA350	33.63	33.90	17.00	15.00	7.50

Spring Return Pneumatic Actuator:

SIZE	A	B	C	D	E	Actuator	F	G	H	L	L1
1/2"	6.17	0.50	2.60	3.09	1.57	SR63.11	8.40	6.61	4.23	3.27	1.85
3/4"	6.65	0.75	2.62	3.33	1.57	SR75.11	8.89	7.24	4.70	3.74	2.09
1"	7.25	1.00	2.66	3.63	1.57	SR83.11	9.30	8.03	5.07	4.05	2.24
1 1/2"	7.17	1.57	2.32	3.59	1.88	SR105.9	10.22	10.55	6.02	4.78	2.52
2"	8.66	1.97	2.76	4.33	1.88	SR125.8	11.53	11.65	6.89	5.59	2.93
2 1/2"	11.10	2.60	3.74	5.55	4.00	SR140.8	15.28	15.35	7.54	5.98	3.03
3"	11.26	2.99	3.78	5.63	4.00	SR160.8	16.32	18.03	8.54	6.86	3.43
4"	13.70	3.94	4.84	6.85	4.00	SR190.9	19.08	20.79	10.24	8.12	4.06
6"	17.56	5.91	7.09	8.78	4.00	SR240.12	23.65	23.70	12.56	10.24	5.12
8"	21.18	7.87	8.15	10.59	6.00	SR350.10	31.15	33.90	17.00	15.00	7.50
10"	27.67	9.84	8.62	13.84	6.00	SR400.14	34.02	36.40	19.40	20.30	10.15
12"	30.31	11.81	10.63	15.16	6.00	CONSULT FACTORY					

Note: Actuator sizing for clean liquid media, and supply air 80 psi.

Electric Actuator Assembly:

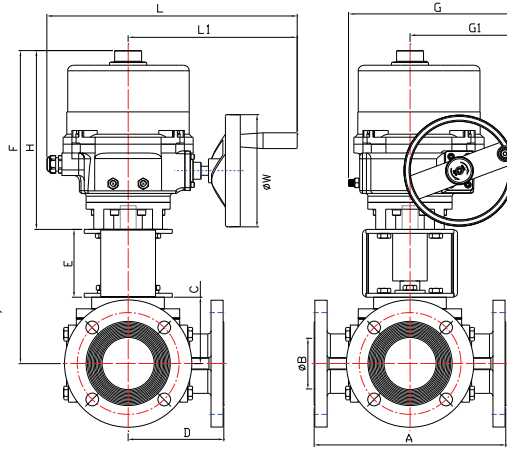

Pneumatic Actuator Dimensions shown in this drawing are for full port units, valves with standard Super-Tek TFM (F) seats, clean fluid only at ambient temperatures, and pressures not to exceed 800 WOG. Consult factory for additional actuator types and dimensional drawings.

All units are generally sized for clean wet service

SIZE	A	B	C	D	E	Actuator	F	G	G1	H	L	L1	W
1/2"	6.17	0.50	2.60	3.09	1.57	ELO-NA4	10.55	4.22	2.11	6.38	4.65	3.25	n/a
3/4"	6.65	0.75	2.62	3.33	1.57	ELO-NA4	10.57	4.22	2.11	6.38	4.65	3.25	n/a
1"	7.25	1.00	2.66	3.63	1.57	ELO-NR6	10.61	4.22	2.11	6.38	4.65	3.25	n/a
1 1/2"	7.17	1.57	2.32	3.59	1.88	ELO-NA8	14.65	7.96	4.85	10.45	14.18	9.45	4.7
2"	8.66	1.97	2.76	4.33	1.88	ELO-NA8	15.09	7.96	4.85	10.45	14.18	9.45	4.7
2 1/2"	11.10	2.60	3.74	5.55	4.00	ELO-NB9	18.19	7.96	4.85	10.45	14.18	9.45	4.7
3"	11.26	2.99	3.78	5.63	4.00	ELO-NA10	20.42	11.42	4.06	12.64	17.61	11.7	7.8
4"	13.70	3.94	4.84	6.85	4.00	ELO-NA10	21.48	11.42	4.06	12.64	17.61	11.7	7.8
6"	17.56	5.91	7.09	8.78	4.00	ELO-NE14	25.98	14.18	4.69	14.89	19.96	13.62	11.5
8"	21.18	7.87	8.15	10.59	6.00	ELO-NF15	29.04	14.18	4.69	14.89	19.96	13.62	11.5
10"	27.67	9.84	8.62	13.84	6.00	ELO-NA16	35.57	14.14	n/a	20.95	19.96	13.62	11.42
12"	30.31	11.81	10.63	15.16	6.00	ELO-NB17	37.58	14.14	n/a	20.95	19.96	13.62	11.42

Gear Operator Assembly:

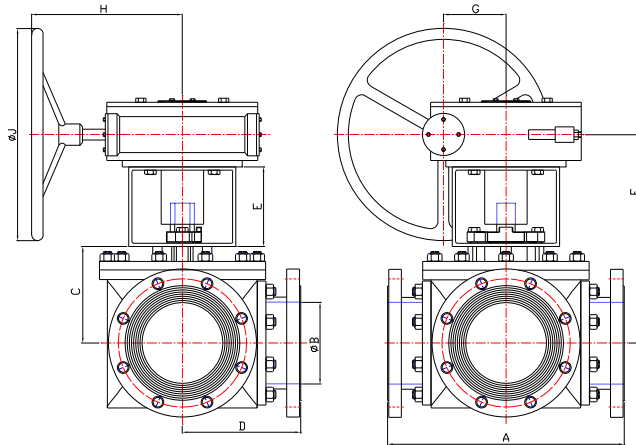

Dimensions are for cost estimation only

3 Way MPF15

Size	Gear Operator	A	B	C	D	E	F	F1	G	H	J
2"	GO2	8.66	1.97	2.76	4.33	1.88	10.78	1.26	1.89	6.14	5.91
2 1/2"	GO-D3	11.10	2.60	3.74	5.55	4.00	17.35	1.46	2.68	9.61	11.81
3"	GO-D3	11.26	2.99	3.78	5.63	4.00	17.39	1.46	2.68	9.61	11.81
4"	GO-D4.5	13.70	3.94	4.84	6.85	4.00	18.01	1.61	3.23	9.17	11.81
6"	GO-D6.8	17.56	5.91	7.09	8.78	4.00	22.27	2.40	4.65	11.18	15.75
8"	GO-D10	21.18	7.87	8.15	10.59	6.00	24.98	4.96	6.57	10.83	11.81
10"	GO-D12	27.67	9.84	8.62	13.84	6.00	25.88	5.59	7.68	11.26	15.75
12"	GO-D14	30.31	11.81	10.63	15.16	6.00	30.88	6.30	9.53	14.25	16.73

3 Way MPF30

Size	Gear Operator	A	B	C	D	E	F	F1	G	H	J
2"	GO2	9.37	1.97	2.76	4.69	1.88	10.78	1.26	1.89	6.14	5.91
2 1/2"	GO-D3	11.22	2.60	3.74	5.61	4.00	17.35	1.46	2.68	9.61	11.81
3"	GO-D3	11.85	2.99	3.78	5.93	4.00	17.39	1.46	2.68	9.61	11.81
4"	GO-D4.5	15.35	3.94	4.84	7.68	4.00	18.01	1.61	3.23	9.17	11.81
6"	GO-D6.8	18.42	5.91	7.09	9.21	4.00	22.27	2.40	4.65	11.18	15.75
8"	GO-D12	23.93	7.87	8.15	11.97	6.00	25.41	5.59	7.68	11.26	15.75
10"	GO-D14	30.27	9.84	8.62	15.14	6.00	28.87	6.30	9.53	14.25	16.73
12"	GO-D14	31.53	11.81	10.63	15.77	6.00	30.88	6.30	9.53	14.25	16.73

Bottom Entry Series

Flow can occur across the ports during ball position change. To avoid this occurrence, you would need a non-transflow design valve. Please see our bottom entry series, Tech Bulletin Page 96



Model: MPF155
Size Range: 2", 3", 4"
Class 150/300/600

Trunnion Design 3 or 4 Way Valves

Please see our Tech Bulletin Page 80

Model: 3W-TM
Size Range: 6"-20"
Class 150/300/600



Tri-Pro Bottom Flow Series

Please see our Tech Bulletin Page 98.

Model: 3W-HPF
Size Range: 1/4" - 2 1/2"
1500 WOG



Special Position Series

120 Degree 3 Way
Piggable Ball Valve

Size Range: 3" - 8"
Class 150



Multi-Port Series

Please see our Multi-Port series, Tech Bulletin Page 100.

Model: MPT100
3 & 4 Way
Size Range: 1/4" - 2"
800 WOG/PSI



Direct Mount 3-Way Series

Please see our Multiport series, Tech Bulletin Page 102.

Model: DM-MPT100
Size Range: 1/2" - 3"
1000 WOG/PSI



3-Way Brass Series

Please see our Multi-Port series, Tech Bulletin Page 105.

Model: MPT355/MPT365
Size Range: 1/4" - 4"
400 WOG/PSI



Transflo - 600 Series

Class 600 3 Way
Ball Valves

Model: MPF60
Size Range: 3" - 12"
Class 600



FLOW PATTERNS

All T-Port Flow Patterns can be changed in the field without disassembling valve

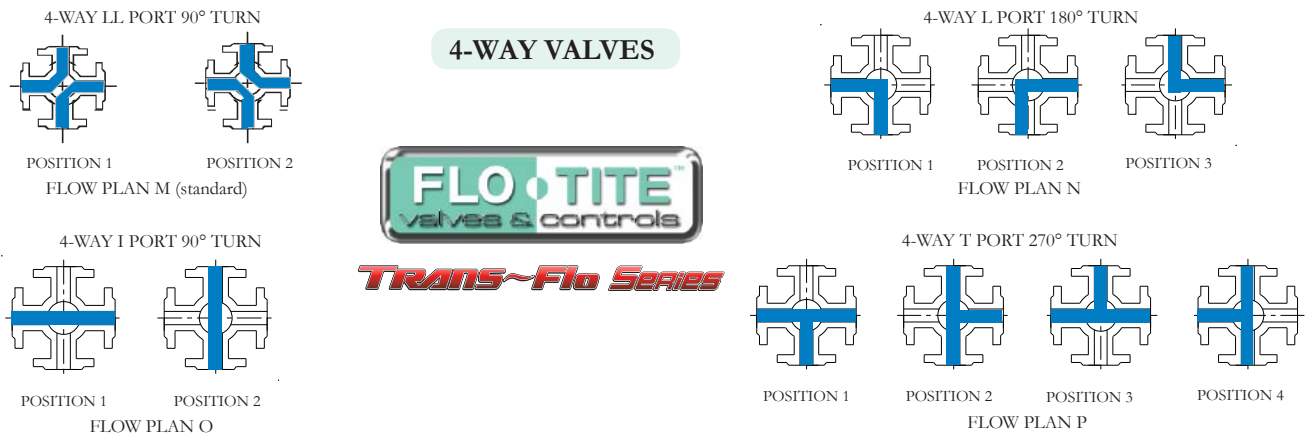

All above standard flow plans are set to move in a counter clockwise 90 degree rotation, moving from position 1 to position 2. Any port can be used as an inlet port. Standard actuated valves also move in a clockwise 90 degree rotation. A clockwise movement can be achieved with a reverse piston change if required. Optional 180 degree, 1 and 2 position is also available, please consult factory.

Non Transflow

Flow can occur across the ports during ball position change. To avoid this occurrence you would need a non-transflow design valve. Please see our bottom entry series, Tech Bulletin page 96 or 98.

Valve Design Flexibility and Travel Stop

Flo-Tite's unique valve design offers excellent flexibility, allowing easy in field re-arrangement of most all flow plans without disassembly. In many cases it can be accomplished as easy as travel stop orientation or repositioning of the valve ball. Please contact factory for detailed additional information on this valuable design feature.

Different travel stops are used to arrange all flow plan selections.

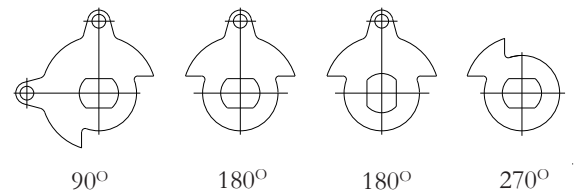

MODEL	BODY MATERIAL		BALL TYPE		VALVE - SOFT PARTS						OPERATOR		SIZE	
					SEAT		STEM SEAL		BODY SEAL				inch	mm
NPT FULL MPT30	316SS	SS	DIVERTER BALL	L	TFM	F	TFM	F	TFM	F	Lever Locking	L	1/4	8
	WCB	CS	T-BALL	T	CTFM	Y	CTFM	Y	RTFM	X			3/8	10
	ALLOY 20	A2	DOUBLE-L	LL	RTFM	X	RTFM	X	PTFE	T	Oval Locking	O	1/2	15
	Bronze	BZ			PTFE	T	PTFE	T	RPTFE	R			3/4	20
CLAMP FULL MPC15	Duplex	DP			RPTFE	R	RPTFE	R	50/50	S	Gear	G	1	25
					50/50	S	50/50	S	UHMWPE	U			Deadman	S
FLANGED FULL MPF 15 MPF 30 MPF 60 MPS15					UHMWPE	U	UHMWPE	U	PEEK	P	Actuator	A	1 1/2	40
					PEEK	P	PEEK	P	GRAPHITE/SS	G			Bare Stem	N
					METAL	M	GRAPHITE	G	KEL-F	K	Special	X	2 1/2	65
					CAVITY FILLED	C							3	80
					KEL-F	K							4	100

Ordering Example By Part Number - Multi-Port Ball Valves:

Tri-Clamp	316SS	DIVERTER	TFM	GRAPHITE	TFM	LEVER	2"	180° Stop
MODEL	BODY MATERIAL	BALL TYPE	SEAT	STEM SEAL	BODY SEAL	OPERATOR	SIZE	*SPECIAL FEATURE
MPC15	SS	- L	- F	G	F	- L	- 50	- K1

5	125
6	150
8	200
10	250
12	300

TRANS~Flo SERIES

Flo-Tite Trans-Flow Series Valves are Available with all Types of Automation.

Flo-Tite TRANS-FLOW series valves are offered as standard with an adjustable packing gland in size 1 1/2" - 12". This feature eliminates the need for removal of automation equipment when stem packing requires a field adjustment.



Flo-Tite offers a complete package of pneumatic, hydraulic, & electric actuators. All types of controls & accessories for a vast number of special automated applications are available.



Flo-Tite, Inc.
4815 West 5th St.
Lumberton, NC 28358

P. O. Box 1293
Lumberton, NC 28359
Website: www.flotite.com

Tel: (910) 738-8904
Fax: (910) 738-9112
E-mail: flotite@flotite.com

Due to continuous development & improvement of our product range, we reserve the right to alter the dimensions and technical data included in this brochure.