

OVC# SS150CK Class 150 Stainless Steel Check Valve

Features

- Face to Face: ASME B16.10
- Design: ASME B16.34
- Flange Dimensions: ASME B16.5
- Test: API 598

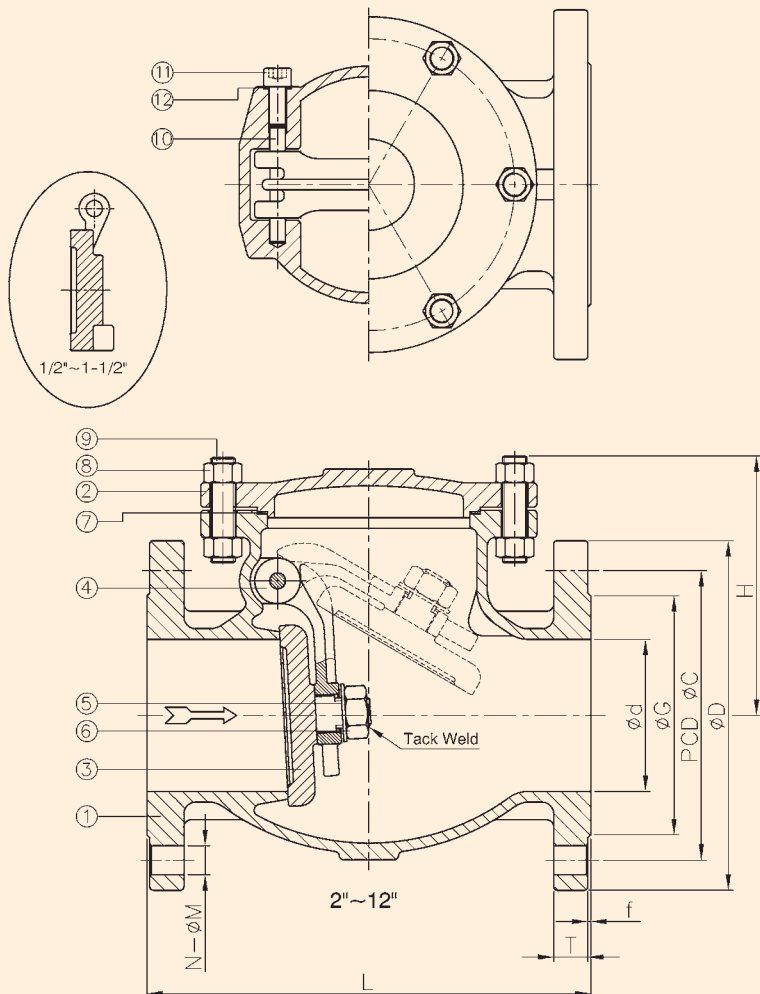

NO.	DESCRIPTION	MATERIAL
1	BODY	ASTM A351-CF8M
2	CAP	ASTM A351-CF8M
3	DISC	ASTM A351-CF8M
4	HINGE	ASTM A351-CF8M
5	FLAT WASHER	AISI 316
6	NUT	AISI 316
7	GASKET A	PTFE
8	NUT	ASTM A194-8
9	STUD	ASTM A193-B8
10	PIN	AISI 316
11	SOCKET HEXAGON SCREW	AISI 316
12	GASKET B	PTFE

NPS	d	G	C	D	H	T	f	N	M	L	Wt./Lbs.
1/2"	0.5	1.37	2.37	3.54	2.28	0.38	0.08	4	0.63	4.25	3.6
3/4"	0.75	1.69	2.75	3.94	2.36	0.38	0.08	4	0.63	4.625	4.6
1"	1	2	3.13	4.33	2.8	0.38	0.08	4	0.63	5	5.9
1-1/2"	1.5	2.87	3.87	4.92	3.27	0.5	0.08	4	0.63	6.5	10.9
2"	2	3.63	4.75	5.91	4.13	0.56	0.08	4	0.75	8	18.9
2-1/2"	2.5	4.13	5.5	7.09	4.76	0.63	0.08	4	0.75	8.5	28.6
3"	3	5	6	7.48	5.98	0.69	0.08	4	0.75	9.5	41
4"	4	6.19	7.5	9.06	6.81	0.88	0.08	8	0.75	11.5	74.5
5"	5	7.31	8.5	10.04	7.68	0.88	0.08	8	0.75	13	on request
6"	6	8.5	9.5	11.02	8.39	0.94	0.08	8	0.88	14	110.9
8"	8	10.63	11.75	13.58	9.61	1.06	0.08	8	0.88	19.5	187.7
10"	10	12.75	14.25	15.94	12.6	1.13	0.08	12	1	24.5	339.5
12"	12	15	17	19.09	13.94	1.19	0.08	12	1	27.5	464.1

* Other sizes available upon request.

TOLL FREE (877) 423-2660 • (513) 752-5600 • FAX (513) 752-8267
 EMAIL sales@ohiovalve.com • WEB www.ohiovalve.com