

OVC# SS200CK

Screwed End Swing Check Valve

Features

- 1/2" ~ 3" (DN15 ~ DN80)
- W.P. : 200 WOG
- W.T. : -20°C~200°C (-4°F~392°F)
- Investment casting
- Socket weld (option)
- Thread type: ASME B1.20.1 (NPT)
DIN2999 & BS21
ISO7/1 & EN10226

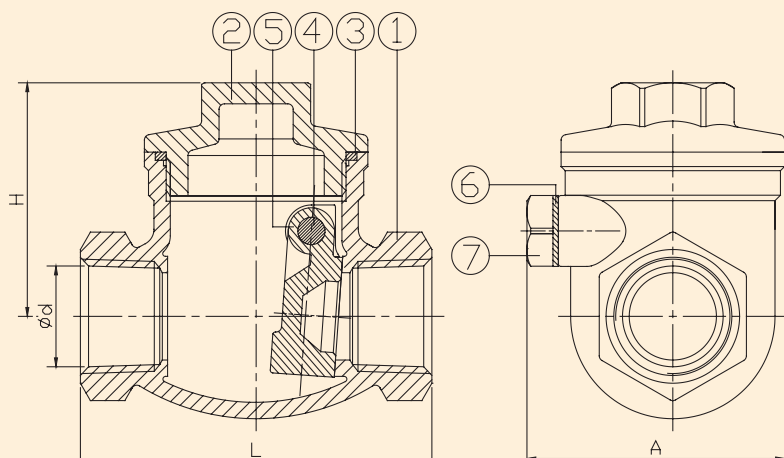

NO.	DESCRIPTION	MATERIAL	
1	BODY	ASTM A351-CF8M	ASTM A351-CF8
2	CAP	ASTM A351-CF8M	ASTM A351-CF8
3	SEAL	PTFE	
4	PLUG	AISI 316	AISI 304
5	DISC	ASTM A351-CF8M	ASTM A351-CF8
6	GASKET	PTFE	
7	BOLT	AISI 304	

NPS	d	L	H	A	Wt./Lbs.
1/2"	0.63	2.56	1.69	1.83	0.7
3/4"	0.79	3.15	2.01	2.03	1
1"	0.98	3.5	2.36	2.2	1.5
1-1/4"	1.26	4.13	2.6	2.52	2.2
1-1/2"	1.57	4.72	2.95	2.93	3.4
2"	1.97	5.47	3.15	3.31	4.7
2-1/2"	2.56	7.13	3.9	4.13	10.1
3"	3.15	7.87	4.09	5.51	16.7

* Other sizes available upon request.

TOLL FREE (877) 423-2660 • (513) 752-5600 • FAX (513) 752-8267
EMAIL sales@ohiovalve.com • WEB www.ohiovalve.com